

**Supplement 18 - POWERPLUS MAXI BMK-050 High-Power Range of Burners**

**18.1 General Information**

This supplement details the instructions and limitations necessary to ensure the safe operation, maintenance and continued airworthiness of the Ultramagic POWERPLUS MAXI BMK-050, range of Burners.

The Powerplus Maxi range of burners is available in double, triple and quad variants. All the variants are provided with the usual burner functions. In addition, the main blast valve is provided with a two-stage mechanism allowing operation of the main burner alone, or simultaneous operation of the main and liquid burners. When operating the main valve in the second (combined main and liquid) position, the output power is approximately doubled. Note that the liquid fire may be operated in isolation using the liquid valve control.

The double burner variant is shown in Figure 1.

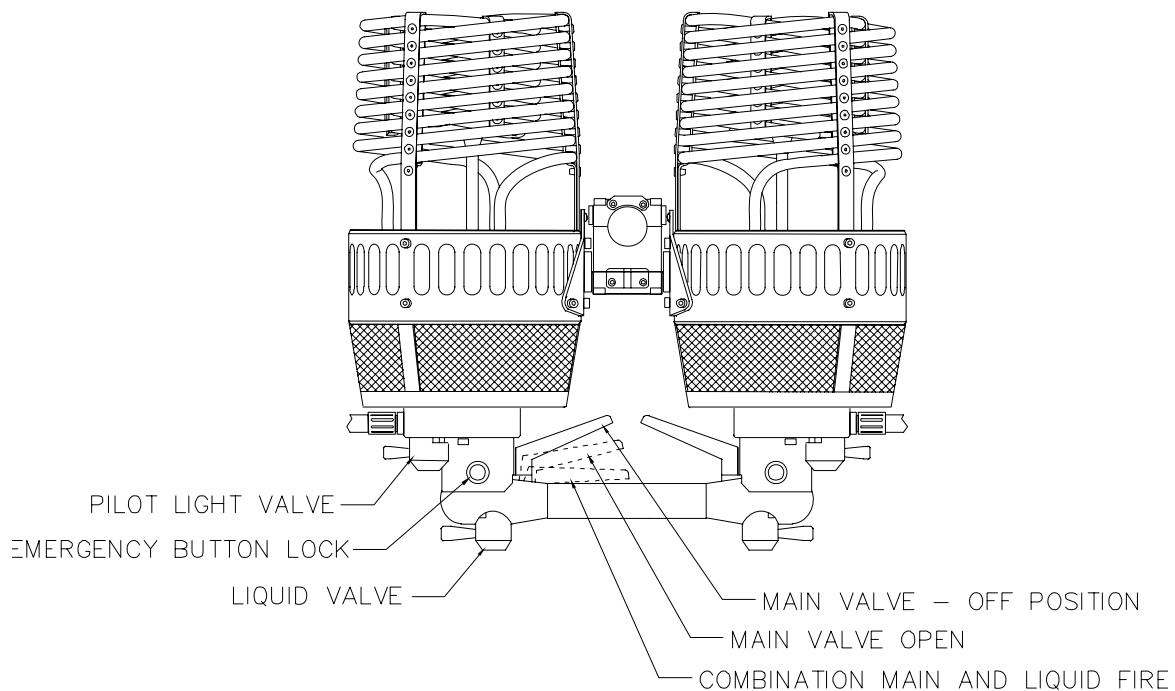
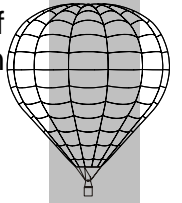

Figure 1

The combination main blast valve is a squeeze action type. The liquid and pilot valves are rotary action.

The burners are provided with an emergency lock button situated on the side of the handle post. This button may be used to hold the main valve in the open position in the unlikely event of a total pilot light failure.



## 18.2 Operational Limitations

### 18.2.1 Minimum Burner Requirements

BMK-050 Burner Variant	Envelope Range Thousand 1000 ft <sup>3</sup>	Envelope Range m <sup>3</sup>
Double	180 – 300	5085 – 8476
Triple	250 – 600	7063 – 16951
Quadruple	350 – 1000	9888 – 28252

### 18.2.2 Maximum Altitude

The maximum allowable altitude for safe burner operation is 21340ft (6500m).

### 18.2.3 Storage Temperature

The burners may only be stored in conditions where the ambient temperature is within the range –25 to +50 degrees Celsius.

## 18.3 Emergency Procedures

### 18.3.1 Pilot Light Failure

If for any reason the pilot light should go out, try to re-light it immediately using the piezoelectric ignition system, matches or other igniters. In case of failure to re-ignite, proceed as follows:

- 1 Close the vapour and liquid take-off valve(s) on the corresponding fuel cylinder.
- 2 Open the main valve on the burner to the first position and depress the emergency-lock button on the side of the handle post so that the main valve is held in the open position.
- 3 Open slightly the liquid take-off valve on the associated fuel cylinder to allow a small flow of fuel.
- 4 Ignite the main burner and regulate the flame using the liquid take-off valve on the cylinder to act as an adequate pilot light.
- 5 Continue to use the liquid fire burner as usual but carefully monitor the burner and cylinder valves for signs of freezing.
- 6 Land as soon as possible.

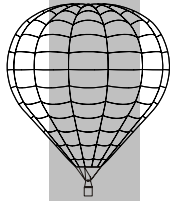

## 18.4 Normal Procedures

### 18.4.1 Testing the Burner

Carry out all checks as described in the Ultramagic Flight Manual. Make the following additional checks:

- Operate the main burner in the first and second positions. Check for correct ignition of the main burner (first position) and then the main and liquid burner (second position).
- Operate the main valve and press the emergency lock button on the side of the handle post. Check that the main valve is held in the open position. Release the lock by gently squeezing the main valve handle.

## 18.5 Loading

No change.

## 18.6 Balloon and Systems Description

No change.

## 18.7 Balloon Maintenance, Handling and Care

No change

## 18.8 Other Manufacturers Equipment

No change.