

Supplement 17 - POWERPLUS BMK-008 Single and Double Range of Burners

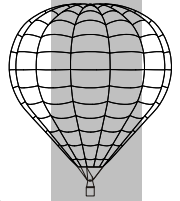

**S
1
7
P
O
W
E
R
P
L
U
S
B
M
K
-
0
0
8
B
U
R
N
E
R
S**

17.1 General Information

This supplement details the instructions and limitations necessary to ensure the safe operation, maintenance and continued airworthiness of the Ultramagic POWERPLUS BMK-008 Single and Double Burners.

The section indexes on this supplement are preceded with the §17.X, and the suffix is kept in line with the Ultramagic Flight Manual: The content of this supplement replaces or appends the information contained on the Flight Manual for the scope to which this supplement is intended.

The “POWERPLUS BMK-008” range of burners has been specially designed to be small and lightweight whilst offering excellent power characteristics. The burners are provided with all the usual functions. In addition, the main blast valve is provided with a two-stage mechanism allowing operation of the main burner alone, or simultaneous operation of the main and liquid burners. When operating the main valve in the second (combined main and liquid) position, the output power is approximately doubled. Note that the liquid fire may be operated in isolation using the liquid valve control. However, the two-stage mechanism can be disabled upon customer reference by applying minor modification Id.179 (refer to UM Maintenance Manual Supplement 11), resulting in a standard-independent-operation of the liquid and main valves.

The burners are shown in Figure 1.

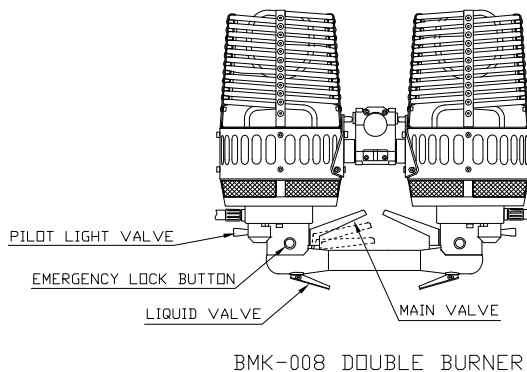
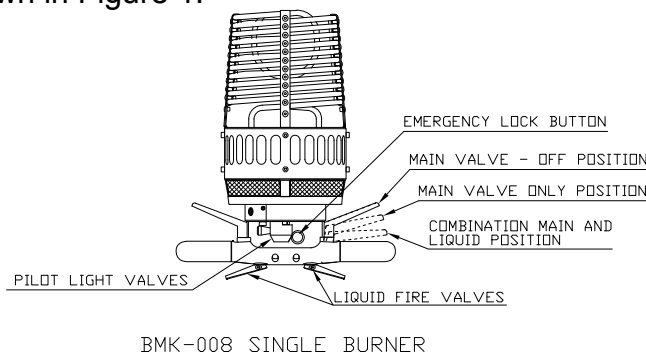
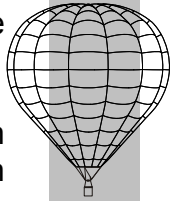

Figure 1



The combination main blast valve is a squeeze action type. The liquid valves are also squeeze action whilst the pilot light valves are rotary action.

Both the Single and Double burners are provided with an emergency lock button situated on the side of the handle post. This button may be used to hold the main valve in the open position in the unlikely event of a total pilot light failure.

Burners implementing minor modification Id.224 are equipped with additional fuel intake valves. These valves are rotary action and are fitted between the fuel hose burner end and the burner itself.

17.2 Operational Limitations

17.2.12 Minimum Burner Requirements

BMK-008 Burner Variant	Envelope Range Thousand 1000 ft ³	Envelope Range m ³
Single	20 - 120	565 – 3390
Double	65 - 210	1836 - 5933

Maximum Altitude

The maximum allowable altitude for safe burner operation is 21340ft (6500m).

Storage Temperature

The burners may only be stored in conditions where the ambient temperature is within the range -25 to +50 degrees Celsius.

17.3 Emergency Procedures

17.3.2 Pilot Light Failure

If for any reason the pilot light should go out, try to re-light it immediately using the piezoelectric ignition system, matches or other igniters. In case of failure to re-ignite, proceed as follows:

- 1 Close the vapour and liquid take-off valve(s) on the corresponding fuel cylinder.
- 2 Open the main valve on the burner to the first position and depress the emergency-lock button on the side of the handle post so that the main valve is held in the open position.
- 3 Open slightly the liquid take-off valve on the associated fuel cylinder to allow a small flow of fuel.
- 4 Ignite the main burner and regulate the flame using the liquid take-off valve on the cylinder to act as an adequate pilot light.
- 5 Continue to use the liquid fire burner as usual but carefully monitor the burner and cylinder valves for signs of freezing.
- 6 Land as soon as possible.

Note: Burners implementing minor modification Id.224 might use the fuel intake valve instead of the liquid take-off valve of the cylinder.

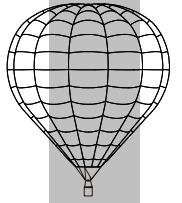

17.4 Normal Procedures

17.4.5 Preparing the aerostat for flight (Add the following)

Use of the Remote Blast Valve Actuator

If the optional remote blast valve actuator is to be used, gently push the button on the actuator and insert it through the slot on the burner valve block just as it is shown in Figure 2. The remote-control handle is used to fire the main blast, alternatively to the default main blast handle.

The remote actuator can be left assembled permanently, although it is recommended to remove it from the burner for road transportation.

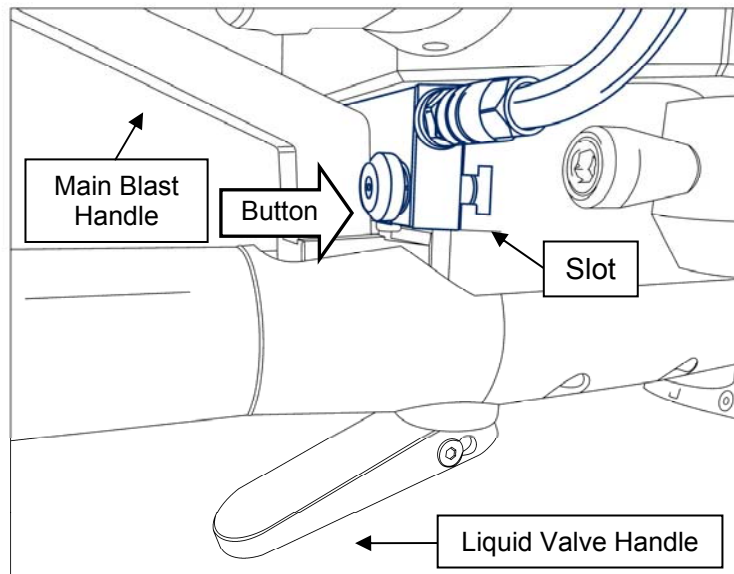

Figure 2

17.4.5.3 Testing the Burner

Carry out all checks as described in the Ultramagic Flight Manual. Make the following additional checks:

- Operate the main burner in the first and second positions. Check for correct ignition of the main burner (first position) and then the main and liquid burner (second position). If the second stage of the main valve is disabled (minor modification Id.179), check that only the main burner flame ignites.
- Operate the main valve and press the emergency lock button on the side of the handle post. Check that the main valve is held in the open position. Release the lock by gently squeezing the main valve handle.
- If the burner features minor modification Id.224 check that the fuel intake valve works properly verifying both closed and open positions.

17.5 Loading

No change.

17.6 Balloon and Systems Description

17.6.2.2.4 Remotely actuated burner valve (Add the following)

The remotely operated main valve is an optional fit on the BMK-008 burners (Ref. minor modification Id.172). This enables the burner valve to be operated without direct actuation on the burner. It does not interfere with the normal valve action of the burner.

System is mounted only onto one side of the burner.

17.7 Balloon Maintenance, Handling and Care

No change

17.8 Other Manufacturers Equipment

No change.

